



★★★★  
MADE IN THE  
USA

# BNP 65 SUCTION BLAST CABINET

EFFICIENTLY AND AFFORDABLY CLEAN, DEBURR, PEEN, OR FINISH PARTS

**IMPORTANT:** For safe, efficient blasting, read and follow the operations manual and seek training for everyone who will use this equipment.



## SAFETY

- Full-length, neoprene-on-fabric gloves resist wear and protect operator.
- Ceiling-mounted, 50W LED light fixture with abrasive resistant cover for extraordinary visibility.
- Safety interlocks interrupt blasting if either door is opened.
- Adjustable, heavy-duty chromed latches seal doors tight through years of service.

## PRODUCTIVITY

- Unique Air Logic system (pilot actuated) to maximize air flow to the blast gun.
- Double-wall, sound-insulated doors, with industrial quality lift-off hinges.
- 14-gauge steel all-welded construction, with precisely formed bends, forms a rigid, long-lasting cabinet shell.

## CONVENIENCE

- Tilt-out window, for tool-free glass changes in minutes.
- Pressure regulator, gauge, and electric switch mounted within easy reach.
- Built-in blow-off gun helps keep dust inside the cabinet, not on your floor.

## COMMON APPLICATIONS

- Remove rust, mill scale, heat scale, and carbon buildup from metals
- Strip paint, powder coating, plating, and anodizing from parts for rework
- Eliminate burrs, parting lines, flashings, and other defects from castings and injection-molded parts
- Extract residual sand from castings
- Beautify steel, stainless steel, aluminum, brass and other metals with a uniform matte finish
- Etch artwork and lettering into glass, stone, plastics, metal and other materials
- Clean release agents and material buildup from molds

## POPULAR ACCESSORIES

- Adjustable gun mount
- Adjustable vortex tube
- Alox Kit (for harsh media)
- Air-powered vertical lift door
- Anti-fatigue mat
- Arm rest assembly
- Curtains (black or white)
- HEPA filter
- Manometer kit
- Noise reduction arm port baffles
- Timed door release
- Two gallon tumble basket
- 20" and 30" dia. turntables with or without work car and foot track extension

## COMPLETE SYSTEM

Space required depends on configurations, options and work flow. Allow space for operator and maintenance access. See maintenance access height (MAH) below.

**Model illustrated:** BBNP-65S-600 CDC-1 / 600 cfm reclaimer.

### BNP-65S

A - 55" deep\*

(\*Includes rear-mounted reclaimer)

B - 42" wide

C - 79" high

### CDC-1

D - 42" deep

E - 34" wide

F - 94" high

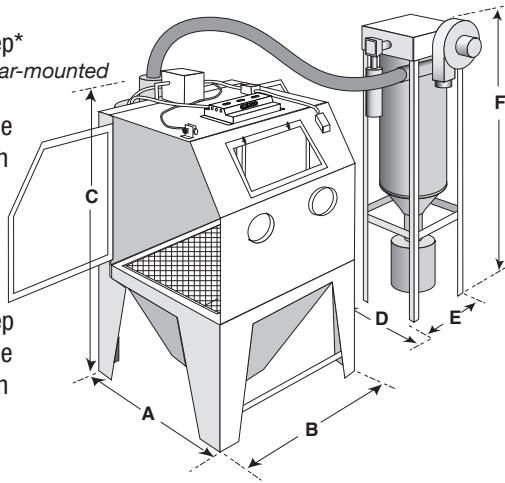

## CABINET

### Working Chamber

- 36" wide (914 mm)
- 35" deep (889 mm)
- 37" high (940 mm)

### Window (safety glass)

- 19.5" wide (495 mm)
- 12.5" high (317 mm)

### Door Opening

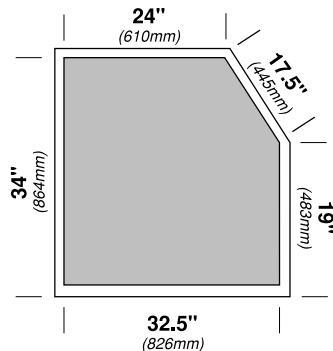

## BLAST RECLAIM SYSTEM

Our exclusive media reclaimers continuously extract dust and debris and return properly sized, usable media to the blast system. The standard reclaimer handles all non-metallic media. For metallic media, choose from the two PM models. The reclaimer, mounted atop the pressure vessel, automatically refills the blast system with clean, recycled media. The versatile design of our larger reclaimers lets you quickly adapt the system to your changing needs.

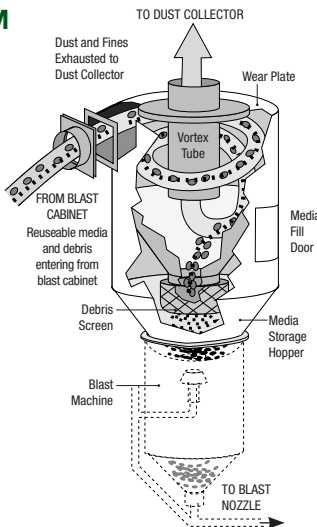

## BLAST GUN WITH CERAMIC NOZZLE

The BNP blast gun sets the industry standard for performance, versatility, and durability. The ergonomic grip reduces operator fatigue and increases productivity. The standard ceramic nozzle is perfect for bead blasting, while the optional tungsten or boron carbide nozzles stand up to hundreds of hours of blasting with today's aggressive abrasives.

## BNP BLAST GUN (AIR CONSUMPTION)

BNP Gun	Nozzle Orifice	Air Jet	CFM at 80 psi	M3/Min at 5,5 BAR	Min Reclaimer
No. 4	5/16"	1/8"	21	0,60	300 CFM(8,5 m3/m)
No. 5	5/16"	5/32"	32	0,90	300 CFM(8,5 m3/m)
No. 6	3/8"	3/16"	48	1,35	600 CFM (17 m3/m)
No. 7	7/16"	7/32"	62	1,76	600 CFM (17 m3/m)
No. 8	1/2"	1/4"	85	2,41	600 CFM (17 m3/m)

BNP 65 cabinets come standard with a No. 5 BNP gun. Consult distributor for advice regarding appropriate recovery size.

## METALLIC MEDIA

For steel media applications, the reclaimer, flex hose, and adaptors must be appropriately sized. Rubber curtains are recommended. "M" in cabinet model signifies cabinet is steel-ready (see below). Contact your local distributor for field conversion information.

## DUST COLLECTORS

**ZERO RP dust collectors trap 99.7% of dust particles down to 0.5 micron.**

**CDC-1:** CDC-1 dust collectors come in three sizes; 300 cfm, 600 cfm, and 900 cfm. The cartridges are pulse-cleaned by pressing the manual pulse-valve to clear the filter of dust. Dimensions are 34" wide, 42" deep (with motor housing) and 94" high. MAH is 11 ft for the 300 cfm and 600 cfm units and 12-1/2 ft for the 900 cfm unit.

## ELECTRICAL

**300 CFM:** (8,5 m3/m) 1/2HP, 115V, 1PH, 60HZ, (.37KW, 220V, 1PH, 50HZ)

**600 CFM:** (17 m3/m) 1HP, 115V, 1PH, 60HZ, (.75KW, 220V, 1PH, 50HZ) (600 CFM model is ISO available with three phase motor. Specify 230v or 460v.)

**900 CFM:** (25 m3/m) 2HP, 220V, 3PH, 60HZ, (1.5KW, 220V, 3PH, 50HZ)

## ORDERING INFORMATION

Model-Recl-D/C	Conv. Single Phase	Conv. Three Phase	Ship Wt. lb (kg)
BNP-65S-300 CDC	28091		765 (347)
BNP-65S-600 CDC	28092	28093	850 (386)
BNP-65SM-900 CDC	28414		1000 (454)